

Stationary Filters Bag Filter Dust Collector

S-SERIES



NOTICE

- ✓ Meets the definition of enclosureless dust collector per NFPA 660-2025 section 3.3.5.4.
(Note: formerly NFPA 664-2020 section 3.3.12.2 and NFPA 654-2020 section 3.3.21)
- ✓ Must be installed per all applicable local, state and federal regulations including NFPA 660-2025 section 9.4.4.5.4 and either 24.9.4.4.5 or 25.9.4.4.5 as applicable.
(Note: formerly NFPA 664-2020 section 9.3.4 or NFPA 654-2020 section 9.3.13.1.1.2)

See NFPA for information on Codes and Standards: <https://www.nfpa.org>

No portion of this manual may be reproduced without the written approval of Nederman.

Original Installation and Service Manual

REV.2 0125



89312882

TABLE OF CONTENTS

Section 1.0Preface.....	3
Section 2.0.....Safety.....	4
Section 3.0.....Introduction.....	5
Section 4.0.....Pre-Installation	6-7
Section 5.0.....Electrical Requirements.....	8
Section 6.0.....Installation.....	9-11
Section 7.0.....System Operation	12-14
Section 8.0.....Maintenance	15-18
Section 9.0.....Spare Parts	19
Section 10.0....Data Sheets	20-22
S-500	20
S-750	21
S-1000	22
Section 11.0 ...Warranty & Returns.....	23

Section 1.0 Preface

1.1 Purpose:

This manual is part of the machine and describes its safe and proper operation.

READ the manual carefully before operating the machine.

Keep the manual in a safe place for the duration of the machine's service life.

Make sure the manual is accessible to personnel at all times.

Pass manual on to each subsequent owner/end user.

1.2 Validity:

This manual is exclusively valid for the machine specified on the title page

1.3 Defining Target Groups:

- Owner/End User - Party operating the machine in conformity with intended purpose or ordering suitable instructed personnel to operate it on their behalf
- Operator - Any personnel instructed to operate the machine
- Electrician - Anyone on the basis of the professional qualifications is familiar with relevant standards and is the only one who can carry out assigned tasks as well as recognize and avert potential hazards.

1.4 Symbols:

Warning signs are used in this manual for safety and avoidance of injury for all involved in the operation of the machine and prevention of damage to the unit. Warnings are divided into the following areas:



WARNING

Non-compliance can lead to death or serious injury



CAUTION

Non-compliance can lead to medium or minor injuries



ATTENTION

Non-compliance can lead to property damage



NOTICE

Information for better/clearer understanding

Section 2.0 Safety

2.1 Operation Safety: **WARNING**

The S-Series is to be used for wood per NFPA 660.

DO NOT operate the machine under the influence of drugs or alcohol.

DO NOT use the collector to pick up liquids or any metal or metal scrap. Metal debris contacting the spinning impeller could produce a spark causing a fire and/or explosion.

DO NOT pick up any material too large to safely pass through the fan impeller.

Do NOT place any body parts or tools near the fan inlet during operation for any reason.

DO NOT allow any metal object to strike the machine frame as it could produce a spark. Note: Sparks can smolder in wood dust for a long time before a fire or flame is detected. If metal contacts metal during operation, immediately turn off the dust collector, unplug the power cord from the outlet or lock the main switch on the power supply and wait for all moving parts to stop. Remove the dust collection bags and empty the dust into an approved air-tight metal container in case of spark and remedy the metal to metal contact problem as needed before resuming operation.

DO NOT allow any open flames or heat sources within 10 feet of machine or containers as suspended dust may cause a fire and/or an explosion.

To prevent static electricity generation in systems with a flammable and explosive atmosphere, ensure that such systems are electrically grounded.

Maintenance work or problems concerning any moving parts must not begin until the entire system has come to a complete stop.

2.2 Operator Safety Wood Dust Hazards: **CAUTION**

- Inhaling wood dust into the lungs can cause breathing problems and lead to lung diseases such as occupational asthma and lung cancer.
- Getting dust in the eyes can cause irritation and damage.
- Skin contact with wood dust can cause ulceration of the skin, irritation and dermatitis.

2.3 Fire Protection/Prevention: **WARNING**

- Operators must observe all relevant laws and regulations.
- Air born fine wood dust is a fire and potential explosive hazard!
- Operators must ensure the no burning or glowing parts can enter the machine.
- Operator must inform external contractors of possible hazards.
- If a fire is suspected or breaks out, press emergency stop button!

Section 3.0 Introduction

The S-Series dust collector is an enclosure-less, simple to setup indoor dust collector available in three sizes, the S-500, S-750 and S-1000 with an operating capacity of 1500-5000 cfm (2549-8495 m³/hr). The S-Series comes equipped with Superbag 2000 XT15 Antistatic Polyester filter bags providing 99% efficiency. The 1760 RPM fan provides quieter operation compared to other indoor dust collection systems.

**NOTICE**

Meets the definition of enclosureless dust collector per NFPA 660-2025 section 3.3.5.4

These operating and maintenance instructions are designed to maximize economy and minimize downtime of your NEDERMAN system. Proper operation and routine maintenance of the system is critical in minimizing downtime, avoiding costly repairs, and maximizing system performance.

Stocking certified Nederman spare parts assists in reducing downtime!

Nederman has certified service partners trained extensively in servicing our machinery. Make sure to choose a certified technician to service your Nederman equipment as they have the correct tools and knowledge to resolve your machinery issues and improve performance. Be sure to ask if your technician is certified by Nederman.

Contact Nederman Customer Service to order service and spare parts:

Nederman Corporation USA
4404-A Chesapeake Drive
Charlotte, NC 28216
336-821-0800

Section 4.0 Pre-Installation

4.1 When Unit is Delivered:

Electrical

Please make sure the voltage specified on the order acknowledgment is consistent with the building voltage prior to install. It is the end user's responsibility to ensure adequate electrical capacity based upon loads which can be provided by NEDERMAN. If the motor starter has been purchased from NEDERMAN, it will be pre-wired to the specified voltage. NEDERMAN does NOT supply any disconnects. It is the end user's responsibility to coordinate ALL wiring with a LICENSED electrician. Motor and motor starter warranties are VOID unless wired by a LICENSED electrician.

Foundation

Units MUST be set and anchored on a level surface.

It is the end user's responsibility to adhere to local building codes that relate to foundation guidelines.

NEDERMAN does NOT provide any recommendations that relate to type of foundation, thickness or construction details.

Permits - ALL permits (building, air or otherwise) are the responsibility of the end user.

4.2 Inspection upon Delivery:

Immediately upon receipt of the equipment, carefully inspect all parts to make certain that the unit is in good condition and that all items listed on the packing list are received. Even though the equipment is properly secured on skids at our factory, it is possible for it to be damaged in transit. Please pay particular attention to the large components such as: the filter fan housing and ducting (if included) for obvious damage.

Note all damages and shortages on the Bill of Lading and take immediate steps to file reports or damage claims directly with the freight carrier. All damages incurred to the unit in transit are the responsibility of the freight company.

Nederman shipment terms: F.O.B./EXW origin and ownership passes to the purchaser once the equipment is loaded and accepted by the freight carrier.

ANY CLAIMS FOR "INTRANSIT" DAMAGE OR SHORTAGES MUST BE BROUGHT AGAINST THE CARRIER BY THE PURCHASER. SAVE THE CONTAINERS AND ALL PACKING MATERIALS FOR POSSIBLE INSPECTION BY THE CARRIER OR ITS AGENT. OTHERWISE, FILING A FREIGHT CLAIM CAN BE DIFFICULT. IF YOU DISCOVER DAMAGES AFTER YOU'VE SIGNED FOR DELIVERY, PLEASE CALL CUSTOMER SERVICE IMMEDIATELY FOR ADVICE.

Section 4.0 Pre-Installation

4.3 Offloading:

The dust collection unit is shipped with the bag house roof (lowered), hopper section and fan pre-assembled. The unit should be offloaded and moved with a forklift truck having a minimum 65" (1.65 m) long forks. It is further recommended that the unit be set directly from the truck to the pad or piers upon which it will be installed (see page 11 for specific instructions).

4.4 Required Equipment: NOTICE

- Forklift Truck (a minimum of 65" (1.65 m) long forks required)
- Screwdriver
- Socket wrenches, metric sizes (or adjustable wrenches)

4.5 Storage Procedures: NOTICE

If the unit cannot be installed immediately, the dust collector components should be stored as follows:

- Motor Starter: Store indoors in a temperature and humidity controlled environment.
- Filter Hopper, Filter Top, and Fan Assemblies: Store off of the ground with all external cavities covered to prevent collection of water.
- Ducting components shipped in boxes: Store indoors, if possible.

The dust collector is intended to be located indoors. If the unit cannot be stored inside immediately, it is recommended that the unit be covered with a tarp or like material in such a way that the unit is not exposed to the outdoor elements/weather.

NOTICE

Exposure to outdoor elements can cause galvanic corrosion affecting the aesthetics of the unit.

Section 5.0 Electrical Requirements

5.1 Electrical connection of electrical control and power supply:

Units with no factory mounted electrical control, require an electrical control that is made according to the Nederman regulations must be connected else there is no guarantee on the product.

5.2 Non-line of Sight Operation:



ATTENTION

If the collector is operated where its function, or non-function, is not directly visible and where a defective filter function may lead to a dangerous situation, the operation of the collector must be monitored by means of a pressure switch providing an immediate malfunction alarm.

5.3 Connection to Power Supply:



NOTICE

- 5 hp (3.7 kW), 7.5 hp (5.6 kW) or 10 hp (7.5 kW) electrical motors are used depending on model. Verify motor and power supply upon receipt of order and consult a certified electrician or maintenance department for any necessary connection accessories.
- Single phase units require a motor starter and 208 V or 230 V, 60 Hz power supply.
- Three phase units require a motor starter and 208 V, 230 V, 480 V or 575 V, 60 Hz power supply (per order) with the necessary amperage for horsepower provided.

5.4 Grounding Instructions:

All collectors must be ground following electrical codes. (see figure below as reference)

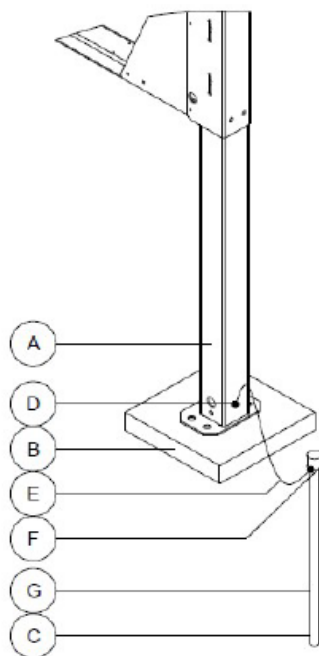

All equipment must be connected to grounding rods

COLLECTOR GROUNDING

- A. STEEL SUPPORT FOR FILTER
- B. FOUNDATION
- C. SOIL. MINIMUM DEPTH 10 ft
- D. CONNECTION 3/8" BOLT AND NUT + CABLE LUG
- E. CABLE CONNECTION. SIZE 10 - 3 AWG, HOWEVER, AT LEAST 50% OF LARGEST CONDUCTOR CONNECTED TO THE SYSTEM, BUT MAX. 3 AWG.
- F. CONNECTION LUG OR BOX FOR GROUNDING ROD.
- G. GROUNDING ROD - COPPER MIN. 1/2" MIN. LENGTH 8 FT (MUST 10 FT INTO GROUND)

Illustration shown as example only.
Contractor must ground according to codes

Section 6.0 Installation

6.1 Introduction:

Assembly and start-up is only to be performed by educated and experienced staff, as errors can damage and/or reduce the lifetime of the filter. These instructions and the safety warnings should be read carefully prior to erecting and start-up.



WARNING

- ✓ Meets the definition of enclosureless dust collector per NFPA 660-2025 section 3.3.5.4
- ✓ Must be installed per all applicable local, state and federal regulations including NFPA 660-2025 section 9.4.4.5.4 and either 24.9.4.4.5 or 25.9.4.4.5 as applicable.

6.2 Main Components:

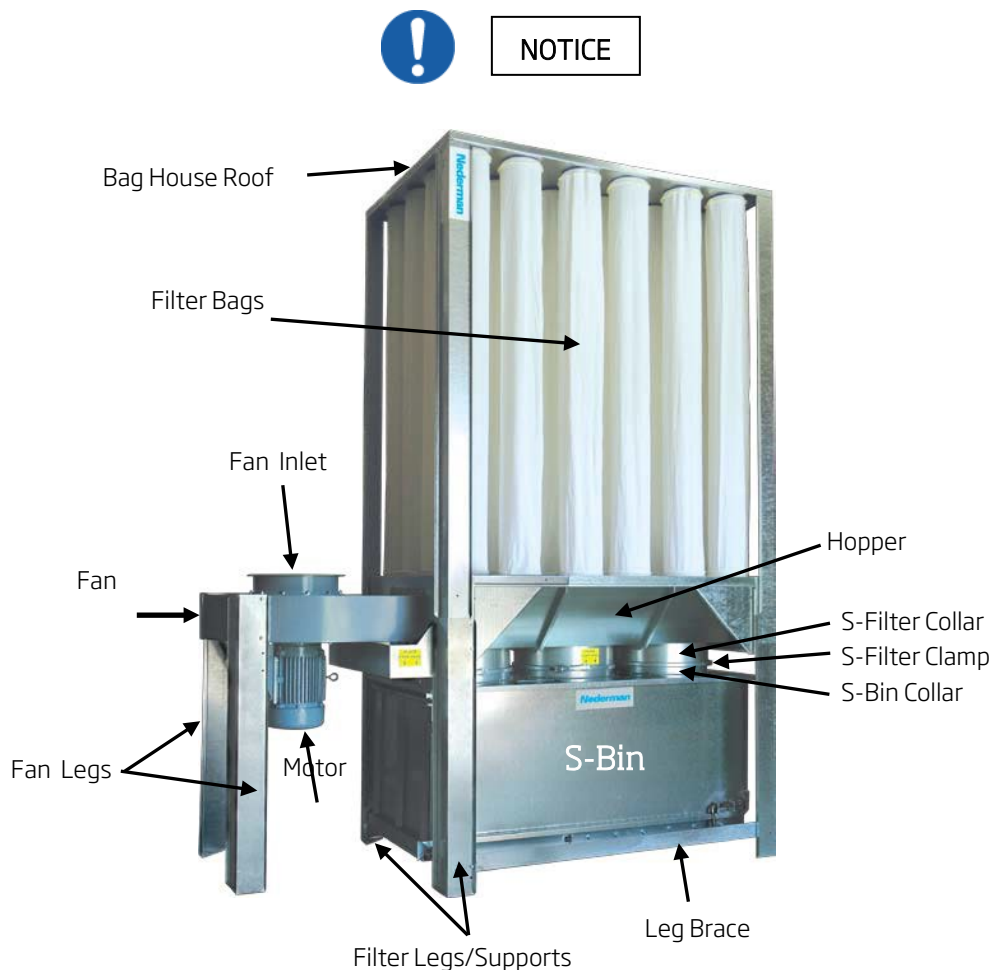

Section 6.0 Installation

6.3 Shipment:

Typically the filter bag house, hopper and fan are delivered as shown below with shrink wrap/film.



NOTICE

The filter unit is shipped with the top/baghouse collapsed.



Section 6.0 Installation

6.4 Off-loading & Set-up:



CAUTION

Step 1

When removing the unit from the skid, locate the decals (as seen below) indicating where to insert/place the forklift forks (*requires a 65" (1.65 m) min length fork*) which will provide even weight distribution and the unit tipping over while moving. *Note: Unit must be placed on a level foundation.*

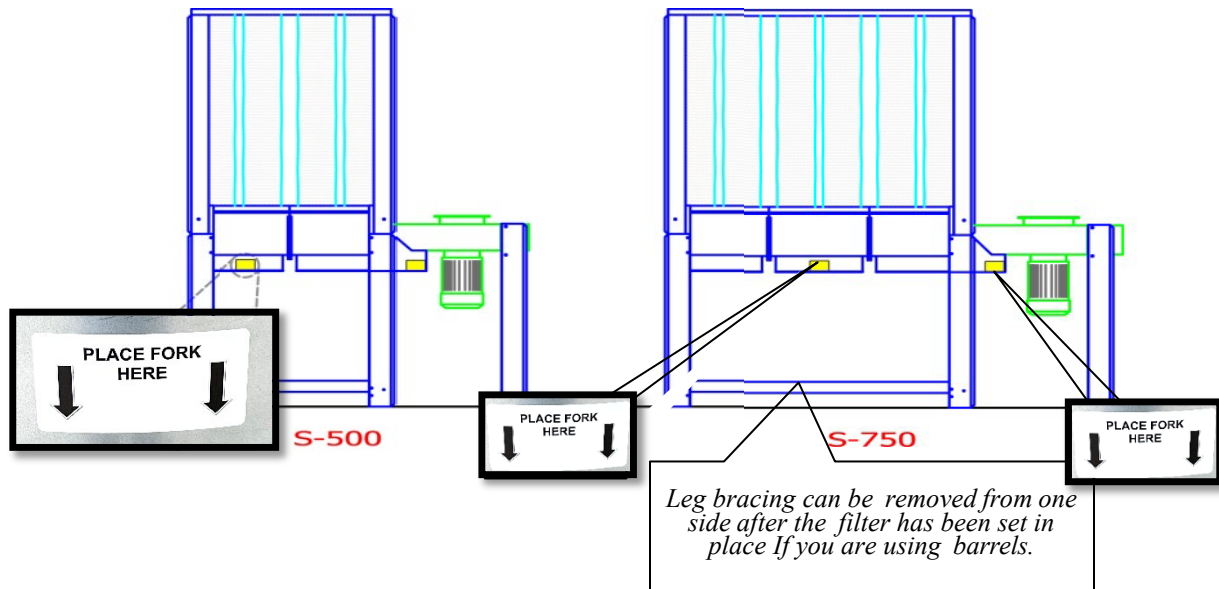

Step 2 - Set-up (raising the bag house roof)

Once the unit is in the desired location, raising the bag house roof requires one person at each of the four legs/corner. (see photo below).



- 1) Unbolt the bag house roof legs from dust collector legs saving the nuts and bolts for step 3.
- 2) While holding the roof legs close to the filter legs, evenly extend/raise the bag house roof and roof legs at the same time.
- 3) Once completely raised, secure the bag house roofs legs in place reusing the nuts and bolts.



NOTICE

Bags have a sewn in snap ring securing bag to the inside of hopper holes.

Section 7.0 System Operation

7.1 How the Dust Collector Works:



NOTICE

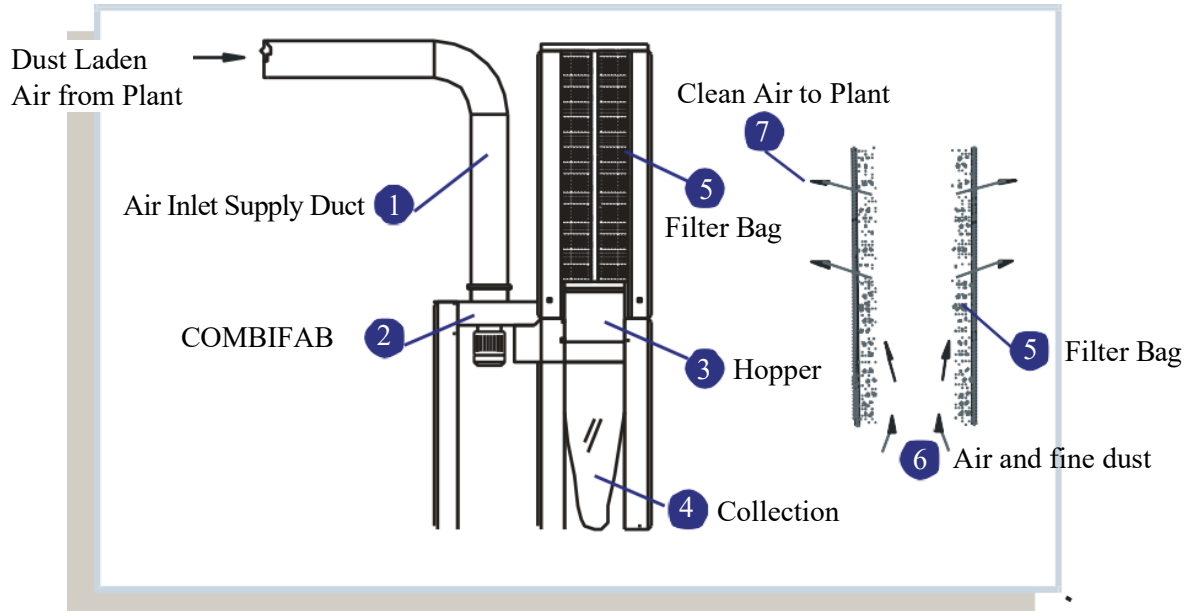

1. The dust laden air from the plant is pulled through the supply duct (item #1) and enters the system via the COMBIFAB fan (item #2).
2. The dust laden air then enters the hopper section (item #3).
3. As the air speed reduces within the hopper, the heavier dust particles will fall down into the collection bags or bins (item #4).
4. The remaining fine dust (item #6) travels up inside of the filter bags (item #5).
5. The clean air (item #7) exits the filter bags into the surrounding atmosphere.

Section 7.0 System Operation

7.2 Cleaning the Bag Filters (ONLY off-line and when fan is stopped)

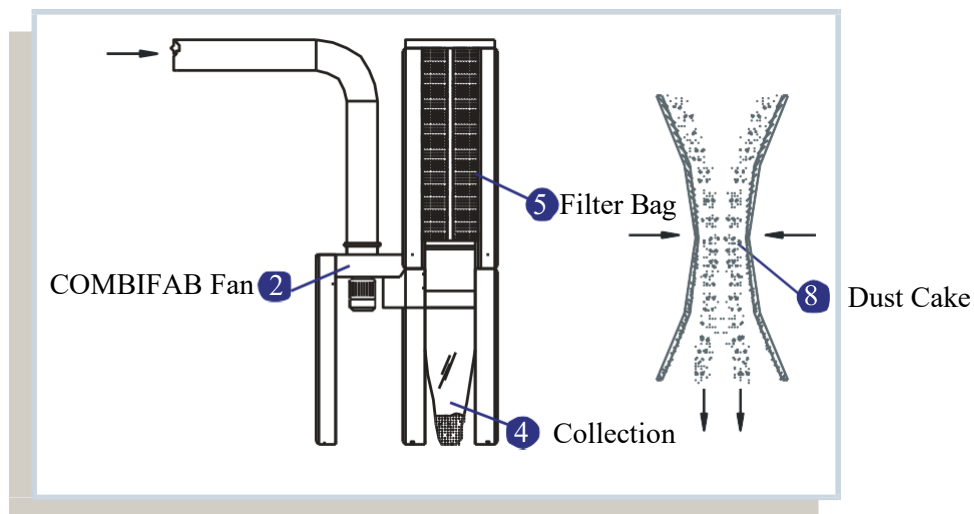

WARNING

It's a fire hazard to clean bags while fan is in motion!

1. Cleaned by applying physical force to the outside of the filter bags (item #5).
Note: Optional manual, mechanical and automatic shaker cleaning systems are available.
2. The dust cake (item #8) hanging on the inside of the filter bag, falls into the hopper sections and then drops into the collection bags or bins (item #4).

7.3 System Awareness:



WARNING

- Read the SAFETY INSTRUCTIONS carefully before commencing any type of activity.
- Not following the safety instructions may lead to serious personal injury.
- Access doors may only be opened in accordance with the safety instructions.
- Authorized personnel may perform adjustment of the electrical controls without cover only when the electrical control is not connected to the supply voltage and in accordance with the current safety rules.
- The operator of this dust collector will normally be working in areas connected by means of a pipe system and not a permanently working at the collector.
- Start/stop is activated by means of an electrical control (normally in connection with start of a fan connected to the filter). Start/stop will often be located near the operator's normal workplace, i.e. physically separated from the collector.

Section 7.0 System Operation

7.4 Operation:

The initial start must take place in accordance with the maintenance and mounting instructions for the S-Series and must be performed by trained authorized personnel.

Normal Start

Pressing the start button on the motor starter connected to the fan activates a normal start. The dust collector can also be started via a signal from an installed external start/stop system.

Normal Stop

A normal stop is made by pressing the stop button on the electrical motor starter or via a signal from an external start/stop system if installed.

Normal stop should not be made by means of the emergency stop button!

Please follow the safety instructions (page 8) in the case of a stop for inspection.

Emergency Stop  NOTICE

In the case of an emergency, the filter can be stopped by activating the emergency stop button.

Emptying of Filter Bags and Containers  CAUTION

Filters should be inspected in accordance with the maintenance instructions in section 8.

Waste/collection containers must be emptied periodically. Before emptying, shut down the dust collector and clean the filter bags manually or with installed shaker cleaning system. Dust laden air is a hazard so goggles, dust mask and gloves should be worn.

Dust should NOT be stored for long periods of time in the waste/collection containers.

The optimal time for emptying the collection containers in applications containing large amounts of fine dust is prior to starting the dust collector so that any inhalable dust is settled.

Disposal of collected dust and debris must be done according to local government guidelines.

=====



NOTICE

Optional shaker filter bag cleaning systems are available with new units and can be retrofitted on units in the field.

Section 8.0 Maintenance



WARNING

Before performing any service or maintenance work on this equipment, the safety procedure and warnings listed below must be followed.

1. Disconnect all power supplies.
NOTE: Equipment may have more than one power supply to disconnect.
2. Lockout-Tag out all disconnected power supplies to prevent equipment being turned on while work is being performed.
3. Personnel accessing the dust compartment must wear proper PPE including breathing equipment and eye protection.
4. When working overhead or in a storage silo, proper supports must be in place to prevent collapse of material above or below the working area.
5. When working overhead or in a storage silo, personnel must wear safety belts with properly attached lifelines.
6. Once service or maintenance is completed, reinstall and safety guards before starting the dust collector

Section 8.0 Maintenance

Please carefully read the SAFETY INSTRUCTIONS in its entirety before commencing any type of activity as there is potential for serious personal injury if not followed.

Only authorized personnel may perform adjustment of the electrical controls without cover, when the electrical control is not connected to the supply voltage and in accordance with the current safety rules.

Please note the following:



WARNING

- Before any type of inspection or maintenance activities are commenced, the dust collector must be completely stopped, the electrical control must be disconnected in such a way that the collector cannot be started inadvertently. The collector should not be started again until all guards, doors etc. Have been restored correctly.
- Only use original NEDERMAN spare parts for repairs.

8.1 Maintenance:

Fan

The fan wheel is carefully balanced at the factory to ensure vibration-free function. Vibrations can arise during operation due to dust deposits on the fan wheel or loose fan wheel bolts. These vibrations should stop once the fan wheel has been cleaned and/or tightened. Contact a certified technician if the vibrations persist after cleaning and tightening of the fan wheel as vibrations can reduce the life of the fan.

Motor

Motor has sealed bearings. Note: Older motors may have a grease fitting and require periodic lubrication of bearings according to the manufacturer's instructions. Over-greasing of bearings can cause premature bearing and/or motor failure. The amount of grease added should be carefully controlled. Bearing life is dependent upon proper use and maintenance.

Filter Bags

The durability and life expectancy of the filter bags are heavily dependent on the operational conditions, filter bag stress, type of dust and dust load but under normal operating conditions and proper maintenance, filter bags should last 3 to 5 years.

Filter bags should be checked frequently for proper attachment to the hopper. Due to the attachment design, it is common to erroneously assume the bags are secured properly. The stainless steel "snap ring" sewn on the inside of the bottom of each bag, must be centered, horizontally, in the cell plate. Extreme areas of wear and tear on certain filter bags may be caused by malfunctions in the operation, and should be checked by a qualified technician.

Section 8.0 Maintenance

During normal operation and even after cleaning, a small dust layer remaining on the inside of the bags assists in the collection.

Fine dust that cannot be blown out will become deposited/trapped in the filter fabric. Therefore, the filter bag will lose its efficiency over time due to these deposits in the fabric and wear and tear. In applications with a high fine dust concentrations, the filter bags should be cleaned mechanically through "beating", "shaking" or via optional shaker systems.

8.2 Service and Repair:

Only specially trained or certified personnel should perform service and repair.

Before any work can begin, the main switch must eliminate the power supply and it must be ensured that no unintended restart can occur. An option would be to lock out and tag out the main switch. Accumulated energy, such as in a compressed air system, must also be interrupted or discharged before commencing the work.

For service and repair work done in the dust laden air, at a minimum the following safety equipment must be used.



CAUTION

- Respiratory Protective Device, possibly with fresh air supplies
- Goggles or shield mask possibly in connection with fresh air supply in toxic dust Applications, supplement with required special equipment. For fire/explosive dust, the following must also be used:
 - Fire Retardant Suit
 - Fire Retardant Working Gloves
 - Safety Footwear
 - Safety Helmet
 - Sparkless tools wherever possible

Inspection of filters from the clean air side/in the clean air chamber should only be performed when the collector system has completely stopped. The personal safety equipment referred to above should be used.

If cleaning is performed using a vacuum cleaner, protection must be provided against static electric charging.

Boring of holes in dust collector housing or adjoining pipe ducts should only be performed only when the system is off, has completely stopped and has been cleaned, While doing so, make sure no heat generated.

Section 8.0 Maintenance

Any item causing an electrical must be removed and repaired or replaced utilizing proper troubleshooting and repair procedures prior to further operation.

Disposal of components, dust/waste from cleaning, as well as other waste, must be performed to the guidelines for the particular materials based on local and federal guidelines. In case of doubt, consult the person responsible for company safety.

8.3 Scheduled Maintenance Check List:

The system should be continuously checked according to the following recommended schedule which is based on a single daily 8 hour shift. Schedule should be adjusted accordingly to increased or decreased operation times.

<u>Check</u>	<u>Interval (Months)</u>
Filter Bags (attachment to hopper, wear & tear)	1 (monthly)
Hopper (dust build up, wear and tear)	1 (monthly)
Fan Bearings (lubrication, bolts)	3 (quarterly)
Bag House (wear and tear, leaking)	6 (bi-annual)
Fan Wheel (lubrication, balance, wear & tear)	12 (annually)

8.4 Recommended Lubricants:

Motor Bearings: The electric motors are pre-greased with a polyurea mineral oil NGLI grade 2 type grease unless stated otherwise on the motor nameplate.

Compatible brands:

- Chevron SRI #2
- Rykon Premium #2
- Exxon Polyrex EM
- Texaco Polystar RB

Section 9.0 Spare Parts

Reduce downtime by stocking certified Nederman spare parts!

	<u>S-500</u>	<u>S-750</u>	<u>S-1000</u>
<i>Filter Bag Requirement (per Unit)</i>	<i>16 Bags</i>	<i>24 Bags</i>	<i>24 Bags</i>
<i>Recommended Filter Bag Safety Stock</i>	<i>4 Bags</i>	<i>4 Bags</i>	<i>2 Bags</i>

Item	Description	Part #	Qty
Filter Bag	S-500/S-750 Superbag - 8.66" x 54.13" (220 mm x 1375 mm)	89251020	1
Filter Bag	S-1000 Superbag XT15 - 8.66" x 77.16" (220 mm x 1960 mm)	89251021	1
Clamp	500 mm QF Clamp (bags, barrels or bin)	8010005736	1
Waste Bag	8 mil Plastic Collection Bag Roll (90 pcs)	89201024	1
Dump Bin	230 gal (871 L) 33"x70.5"x36.5" (838 mmx1790 mmx927 mm)	89101011	1
Barrel	45 gal (170 L) Collection Barrel	8030000209	1
<i>Shaker Filter Bag Cleaning Kits (see Shaker IOM)</i>			
Shaker Kit	S-500 Manual	89101071	1
Shaker Kit	S-500 Mechanical	89101072	1
Shaker Kit	S-500 Automatic - 208-230 V/460 V	89101073	1
Shaker Kit	S-500 Automatic - 575 V	89101074	1
Shaker Kit	S-750 & S-1000 Manual	89101075	1
Shaker Kit	S-750 & S-1000 Mechanical	89101076	1
Shaker Kit	S-750 & S-1000 Automatic - 208-230 V/460 V	89101077	1
Shaker Kit	S-750 & S-1000 Automatic - 575 V	89101078	1
<i>Shaker Upgrade Kits (See Shaker IOM for more information)</i>			
Shaker Kit	Manual to Mechanical	89101079	1
Shaker Kit	Manual to Automatic - 208-230 V/460 V	89101080	1
Shaker Kit	Manual to Automatic - 575 V	89101081	1
Valve	Shut Off Valve (Shaker Kit replacement)	89101082	1
Reg/Filter	Regulator & Filter Combo (Shaker Kit replacement)	89101083	1

Section 10.0 Data Sheets - S-500

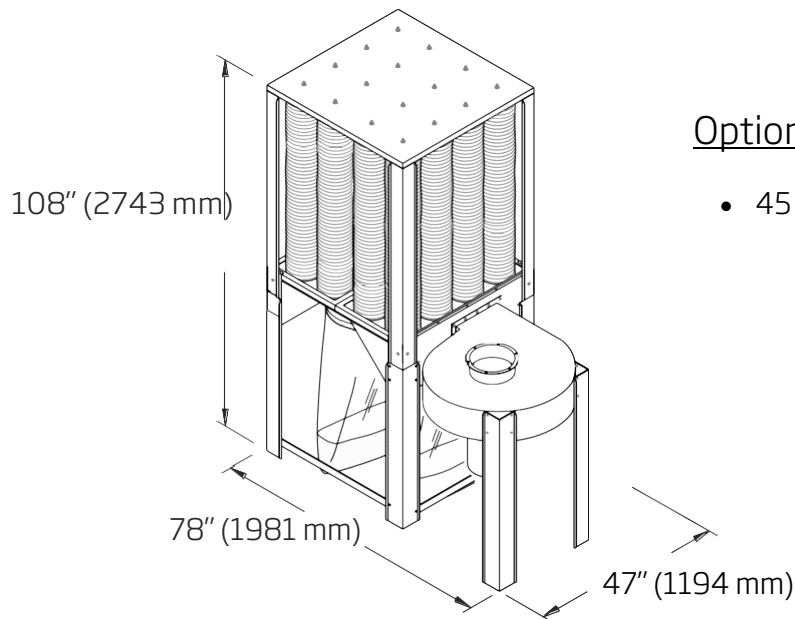
Optional Collector:

- 45gal (170 L) Barrel

Design	Floor model for indoor use
Specifications	Inlet hole size: 9.84" (250 mm)
	Filter bag size: 8.66" (220 mm) x 54.13" (1375 mm)
	Filter bag qty.: sixteen (16)
	Filter bag: Superbag 2000 XT15 Antistatic Polyester
	Filter area per bag: 10.125 ft ² (0.94 m ²) Total Filter area: 162 ft ² (15 m ²)
	Air flow capacity: 1500-3000 cfm (2549 -5097 m ³ /hr)
	Static pressure: w.g. = inches of H ₂ O (Pa)
	8.0" (1993 Pa) @ 1,500 cfm (2549 m ³ /hr)
	7.5" (1868 Pa) @ 2,000 cfm (3398 m ³ /hr)
	5.0" (1245 Pa) @ 3,000 cfm (5097 m ³ /hr)
Dimensions	Base: 47" (1194 mm) x 78" (1981 mm)
	Height: 108" (2743 mm)
	Weight/Shipping Weight: 656 lbs. (295 kg) / 880 lbs. (399 kg)
Construction	Collector: Pre-formed galvanized steel
Motor	Type: TEFC capacitor-start induction
	Size: 5 hp (3.7 kW)
	Phase/voltage: Single Phase 208 V
	3 Phase 208-230 V/460 V
	Frequency: 60 Hz
	Speed: 1760 rpm
	Activation: On/Off push button
	Bearings: factory lubricated

Section 10.0 Data Sheets - S-750

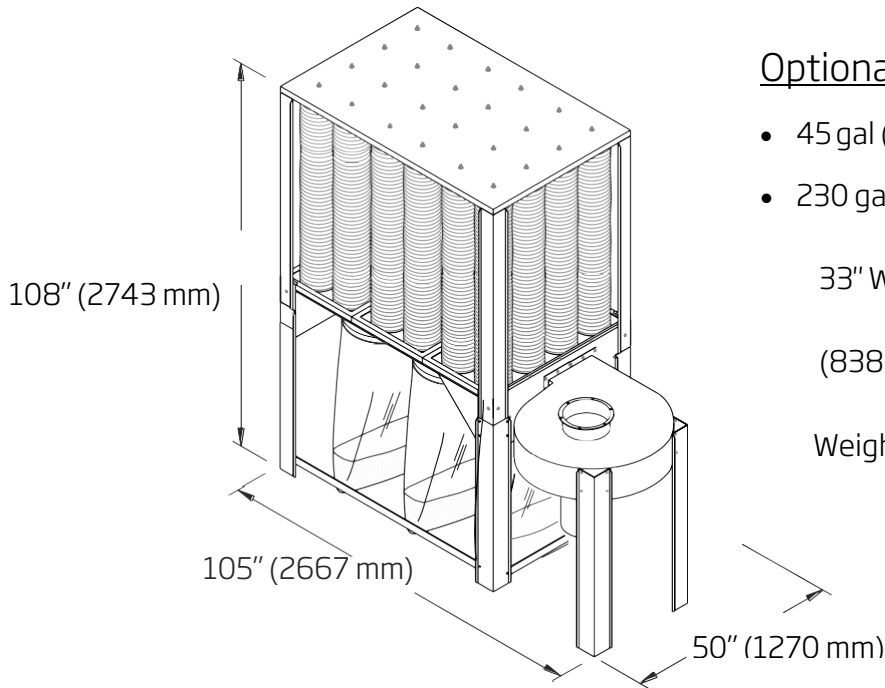
Optional Collectors:

- 45 gal (170 L) Barrel
- 230 gal (871 L) Collection Bin

33" W x 70.5" L x 36.5" H

(838 mm x 1790 mm x 927 mm)

Weight: 500 lbs. (227 kg)

Design Floor model for inside use

Specifications Inlet hole size: 11.02" (280 mm)

Filter bag size: 8.66" (220 mm) x 54.13" (1375 mm)

Filter bag qty.: twenty-four (24)

Filter bag: Superbag 2000 XT15 Antistatic Polyester

Filter area per bag: 10.125 ft² (0.94 m²) Total Filter area: 243 ft² (22.6 m²)

Air flow capacity: 2,500-4,500 cfm (4248 - 7646 m³/hr)

Static pressure: wg = in of H₂O (Pa)

10.0" (2491 Pa) @ 2,500 cfm (4248 m³/hr)

8.0" (1993 Pa) @ 3,500 cfm (5947 m³/hr)

6.0" (1495 Pa) @ 4,500 cfm (7646 m³/hr)

Dimensions Base: 50" (1270 mm) x 105" (2667 mm)

Height: 108" (2743 mm)

Weight/Shipping Weight: 805-865 lbs. (365-392 kg) / 1100-1165 lbs. (499-528 kg)

Construction Collector: Pre-formed galvanized steel

Motor Type: TEFC capacitor-start induction

Size: 7.5 hp (5.6 kW)

Phase/voltage: 1 phase 230 V, 3 phase 208-230/460 V or 3 phase 575 V

Frequency: 60 Hz

Speed: 1760 rpm

Activation: On/Off push button

Bearings: factory lubricated

Section 10.0 Data Sheets - S-1000

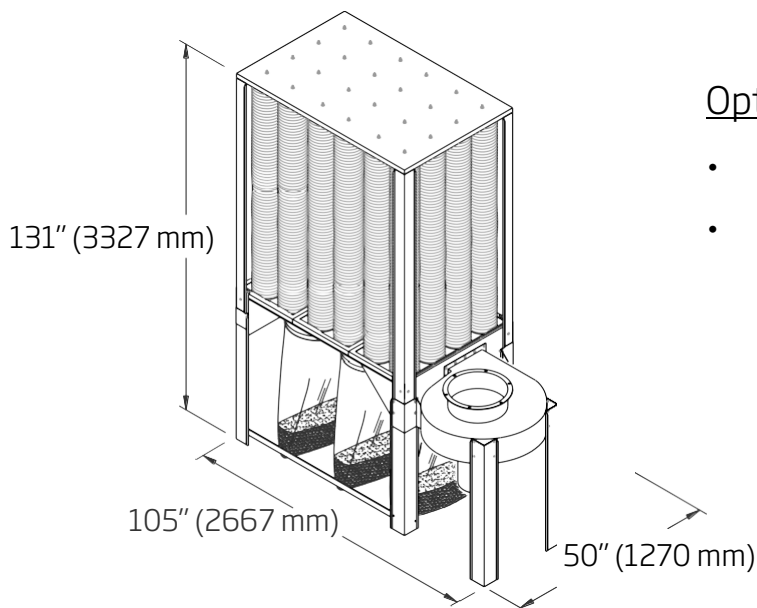
Optional Collectors:

- 45 gal (270 L) Barrel
 - 230 gal (871 L) Collection Bin
- 33" W x 70.5" L x 36.5" H
(838 mm x 1790 mm x 927 mm)
- Weight: 500 lbs. (227 kg)

Design Floor model for indoor use

Specifications Inlet hole size: 15.74" (400 mm)

Filter bag size: 8.66" (220 mm) x 77.16" (1960 mm)

Filter bag qty.: twenty-four (24)

Filter bag: Superbag 2000 XT15 Antistatic Polyester

Filter area per bag: 15.00 ft² (1.4 m²) Total Filter area: 360 ft² (33.45 m²)

Air flow capacity: 4,000-5,000 cfm (6796 - 8495 m³/hr)

Static pressure: wg = in of H₂O (PA)

8.0" (1993 Pa) @ 4,000 cfm (6796 m³/hr)

7.0" (1744 Pa) @ 5,000 cfm (8495 m³/hr)

Dimensions Base: 50" (1270 mm) x 105" (2667 mm)

Height: 131" (3327 mm)

Weight/Shipping weight: 1000-1060 lbs. (454-481 kg) / 1160-1220 lbs. (526-553 kg)

Construction Collector: Pre-formed galvanized steel

Motor Type: TEFC capacitor-start induction

Size: 10 hp (7.5 kW)

Phase type/voltage: 3 phase 208-230/460 V or 3 phase 575 V

Frequency: 60 Hz

Speed: 1760 rpm

Activation: On/Off push button

Bearings: factory lubricated

Section 11.0 Warranty & Returns

11.1 Warranty:

The Seller warrants that the products sold hereunder conform to any applicable drawings and specifications accepted in writing by Seller and will be free from any defects in material and workmanship which become apparent under normal use, and of which Buyer gives written notice to Seller within a period of 6 months from the date of installation or 12 months from the date of shipment, whichever period first expires. If, within that period, the Seller receives from Buyer written notice of any alleged defect in or non-conformance of any product and if, in Seller's sole judgement, the product does not conform or is found to be defective in material or workmanship, then the Buyer shall at Seller's request, return the part or product F.O.B Seller's shipping point and Seller at its option and expenses, shall repair or replace the defective part or product or repay the Buyer the full price paid for such part or product by Buyer.

Dismounting and reinstallation defective or non-conforming parts is done on Buyer's expense. Warranty for delivery of spare parts or replacement of non-conforming parts expires when warranty for original equipment expires. Any repayment of purchase price shall be without interest. Seller's sole responsibility, and Buyer's exclusive remedy hereunder shall be limited to such repair, replacement, or repayment of the purchase price as above provided. THERE ARE NO OTHER WARRANTIES, EXPRESSED, STATUTORY OR IMPLIED, INCLUDING OF MERCHANTABILITY, QUALITY OR FITNESS FOR PURPOSE, NOR ANY AFFIRMATION OF FACT OR REPRESENTATION WHICH EXTENDS BEYOND THE DESCRIPTION ON THE FACE HEREOF. The warranties of Seller do not cover and Seller makes no warranty with respect to:

- a) Failures not reported to seller during warranty period specified above
- b) Failure or damage due to misapplication, abuse, improper installation or abnormal conditions of temperature, dirt or corrosive matter
- c) Failures due to operation, either intentional or otherwise, above rate capacities or in an otherwise improper manner
- d) Products which have been in any way tampered with or altered by anyone other than an authorized representative of Seller.
- e) Products damaged in shipment or otherwise without fault of Seller.
- f) Expenses incurred by Buyer in an attempt to repair or rework any alleged defective product and defects in material and workmanship which are attributable to drawings and specifications provided by Buyer

11.2 Returns:

Please contact NEDERMAN customer service if a part needs to be returned.

If approved by NEDERMAN, a return goods authorization number (RGA#) will be issued and must be indicated on the return package.

Nederman

The Nederman Group is one of the World's leading suppliers of products and solutions within the environmental technology sector focusing on industrial air filtration and recycling. These products and solutions reduce the environmental impact of industrial production and create safe and clean working environments while boosting production efficiency.

The group's offering covers the design stage through installation, commissioning and servicing with subsidiaries in 29 countries and agents and distributors in over 30 countries.

Nederman is ISO 9001 and 14001 certified and develops and produces in its own manufacturing and assembly facilities in Europe, North America and Asia.

Nederman Service Capabilities

Nederman has certified service partners trained extensively in servicing our machinery. Make sure to choose a certified technician to service your Nederman equipment as they have the correct tools and knowledge to solve any machinery issues and improve its performance. Be sure to ask if your technician is certified by Nederman.

Our services for dust collection systems are customized to your particular needs. We work with you to understand your needs, then develop a program to meet your specific needs. Our services include: *(not all services available in all locations)*

- Bag Change-outs
- Bag Selection Recommendations
- Collector Re-builds
- Dye Testing for Leakage
- Electrical Tests - Current, Voltage
- Emergency Call-outs
- Filter Media Analysis
- Mechanical Survey and Repair
- Multi-year Contracts
- New Collector Start-up Service
- On-going Technical Support
- Preventative Maintenance Programs
- Repair and Replace
Gauges/Timers/Valves
- Stack Emission Testing
- Training Programs
- Troubleshooting / Auditing
- Velocity, Pressure and Temperature Tests
- Written Service Report

Customer Service and Technical Support

Nederman Corporation USA
4404-A Chesapeake Drive
Charlotte, NC 28216
336-821-0800

www.nederman.com